

Pronto Series - P2

2-leg Electric Height Adjustable Table Base

Quick Install Quick Ship



LONE STAR ERGO

877-746-2055 | LoneStarErgo.com

Pronto Series - P2

2-leg Electric Height Adjustable Table Base

FEATURES

- Dual motor lifting system
- 2-Stage height adjustability
- Steel frame/foot construction (dual crossbar)
- Height range: 26.1" – 45.75"
- Total height range: 19.65"
- Speed: 1.0"/Second
- Frame width: 40.75" – 68.31"
- Quick install adjustable frame
- Accommodates work surfaces 40" W to 72" W
- Maximum weight load: 300 lbs.
- Low standby power consumption
- Anti-collision & Gyro built-in
- Meets or exceeds BIFMA x5.5 guidelines
- Base is UL Listed E340036
- Includes 8.0' power cord
- Warranty: 10 yr. on electrical components
life time on structural components

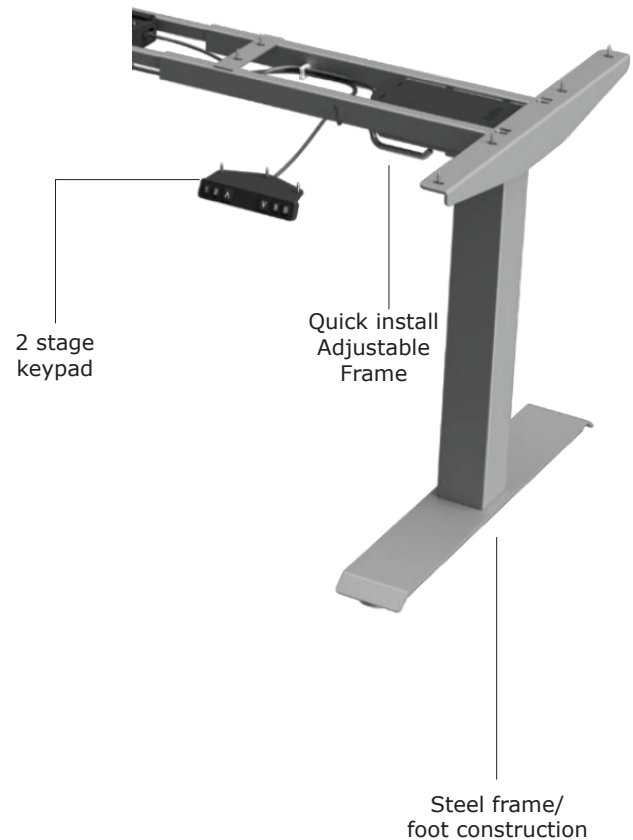

OPTIONS

Available Colors

- Silver (SLV)
- Black (BLK)
- White (WHT)

Handset Options

- 3 memory touchpad with digital readout

Feet Options

- T Shape
- 24" or 30" Length Available

PRODUCT CODE:

LIST PRICE: \$1,100 (Base Only)

LSE-P2-T-*_*-*_*_*

**Feet options

- T shape: 24" or 30"

***Available colors

- Silver (SLV)
- Black (BLK)
- White (WHT)

LONE STAR ERGO

877-746-2055 | LoneStarErgo.com