

# 2023 Price Guide

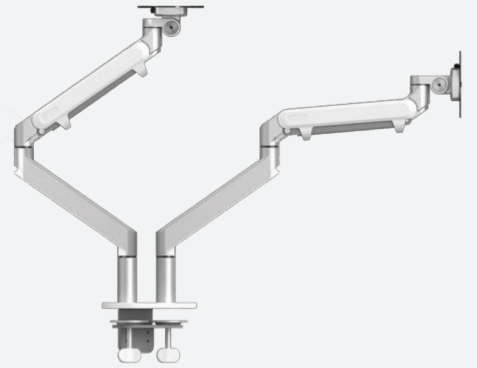



# Table Base Series

PRODUCT	FEATURES	MODEL NUMBER & LIST PRICE
---------	----------	---------------------------

**Alamo A2**



- Dual motor lifting system
- 2-Stage height adjustability
- Steel frame/foot construction (dual crossbar)
- Height range: 26" – 44"
- Total height range: 18"
- Speed: 1.2"/Second
- Frame width: 42" – 72"
- Accommodates work surfaces:
  - 24"D – 36"D
  - 48"W – 84"W
- Maximum weight load: 300 lbs. (including top)

LSE-A2-T-\*\_\*-\*\_\*\_\*

\*\*Feet options  
- T shape: 24" or 30"

\*\*\*Available colors  
● (SLV)  
● (BLK)  
○ (WHT)

**\$1,029 (Base Only)**

**Alamo A3**



- Dual motor lifting system
- 3-Stage height adjustability
- Steel frame/foot construction (dual crossbar)
- Height range: 21.5" – 47.5"
- Total height range: 26"
- Speed: 1.6"/Second
- Frame width: 42" – 72"
- Accommodates work surfaces:
  - 24"D – 36"D
  - 48"W – 84"W
- Maximum weight load: 300 lbs.

LSE-A3-T-\*\_\*-\*\_\*\_\*

\*\*Feet options  
- T shape: 24" or 30"

\*\*\*Available colors  
● (SLV)  
● (BLK)  
○ (WHT)

**\$1,200 (Base Only)**

**Pronto P2**



- Dual motor lifting system
- 2-Stage height adjustability
- Steel frame/foot construction (dual crossbar)
- Height range: 26.1" – 45.75"
- Total height range: 19.65"
- Speed: 1.0"/Second
- Frame width: 40.75" – 68.31"
- Quick install adjustable frame
- Accommodates work surfaces 40" W to 72" W
- Maximum weight load: 300 lbs.

LSE-P2-T-\*\_\*-\*\_\*\_\*

\*\*Feet options  
- T shape: 24" or 30"

\*\*\*Available colors  
● (SLV)  
● (BLK)  
○ (WHT)

**\$1,100 (Base Only)**

**Pronto P3**



- Dual motor lifting system
- 3-Stage height adjustability
- Steel frame/foot construction (dual crossbar)
- Height Range: 21.1" – 47.2"
- Total Height Range: 26.1"
- Speed: 1.4"/Second
- Frame Width: 40.75" – 68.31"
- Quick Install Adjustable Frame
- Accommodates work surfaces 40" W to 72" W
- Maximum Weight Load: 300 lbs.

LSE-P3-T-\*\_\*-\*\_\*\_\*

\*\*Feet options  
- T shape: 24" or 30"

\*\*\*Available colors  
● (SLV)  
● (BLK)  
○ (WHT)

**\$1,272 (Base Only)**

**Pronto P33**



- Triple motor lifting system.
- 3-Stage height adjustability
- Steel Frame/foot Construction (dual crossbars)
- Height Range 21.1" – 47.2"
- Total Height Range 26.1"
- Speed 1.4"/Second
- Quick Install with 3 Frame adjustments:
  - 90 / 120 / Linear
- Frame Width:
  - 90 Degree: 59.1" – 82.2"
  - 20 Degree: 53.9 – 83.9"
  - Linear: 86.5" – 134"
- Accommodates Worksurface:
  - 90 Degree: 60" – 86"
  - 120 Degree: 54" – 84"
  - Linear: 87" – 134"
- Maximum Weight Load: 380 lbs

LSE-P33-T-\*\_\*-\*\_\*\_\*

\*\*Feet options  
- T shape: 24" or 30"

\*\*\*Available colors  
● (SLV)  
● (BLK)  
○ (WHT)

**\$1,845 (Base Only)**



# Desktop Power

PRODUCT	FEATURES	MODEL NUMBER & LIST PRICE
---------	----------	---------------------------

2-Outlet Desktop Power



- 1 USBC type-A and 1 type-C port
- 2 120 VAC outlets
- Product size: 8"x5.43"x1.2"
- Hanger accessories/back clip
- Single port on work: USB 18w/type-C 18w
- Double on ports work: USB 3W+type-C 15w
- Rated power: 1440w
- Current output: 12A
- Input/output voltage: 110v-125v
- USB output power: 5v 2.1A Compatability QC 2.0

LSE-DP-2-\*\_\*\_\*

\*\*\*Available colors

- (SLV)
- (BLK)
- (WHT)

**\$295.00**

3-Outlet Desktop Power



- 1 USBC type-A and 1 type-C port
- 3 120 VAC outlets
- Product size: 8.42"x2.32"x1.2"
- Hanger accessories/back clip
- Single port on work: USB 18w/type-C 18w
- Double on ports work: USB 3W+type-C 15w
- Rated power: 1440w
- Current output: 12A
- Input/output voltage: 110v-125v
- USB output power: 5v 2.1A Compatability QC 2.0

LSE-DP-3-\*\_\*\_\*

\*\*Feet options

- T shape: 24" or 30"

\*\*\*Available colors

- (SLV)
- (BLK)
- (WHT)

**\$340.00**



# Monitor Arms Series

PRODUCT	FEATURES	MODEL NUMBER & LIST PRICE
---------	----------	---------------------------

Maverick Single



- Clamps on to any surface
- Quick release VESA mount
- Universal monitor hardware
- Aluminum Construction
- Accommodates 14" – 32" monitor
- Height Range: 9" – 44"
- Rotates 360°
- Weight Capacity: 4.4 – 19.7 lbs.
- Lift Range: 10.2" – 19.8"
- Tilt: +90° -50°
- Limited lifetime warranty

LSE-MA-S-C- \*

\*Available colors  
 ● Silver (S)  
 ● Graphite (G)

**\$425.00**

Maverick Dual

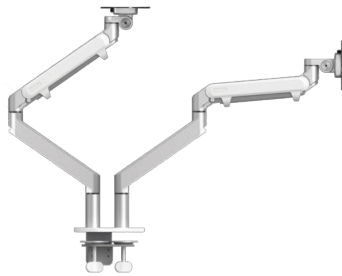

- Clamps on to any surface
- Quick release VESA mount
- Universal monitor hardware
- Aluminum Construction
- Accommodates 14" – 32" monitors
- Height Range: 9" – 44"
- Rotates 360°
- Weight Capacity: 4.4 – 19.8 lbs.
- Lift Range: 10.2" – 19.8"
- Tilt: +90° -50°
- Limited lifetime warranty

LSE-MA-D-C- \*

\*Available colors  
 ● Silver (S)  
 ● Graphite (G)

**\$615.00**



# Peds



PRODUCT	FEATURES	MODEL NUMBER & LIST PRICE
---------	----------	---------------------------

Standard



- Mobile Box/File Cabinet
- Locking 2 drawer cabinet (2 Keys)
- Small top drawer with pencil tray
- Large bottom file drawer
- Steel Construction
- Fits under all height adjustable desks
- Cushions available
- Product Size:
  - Standard: 15.4"W x 19.7"D x 18.5"H

LSE-MPBF-15-\*\_\*\_\*

\*\*\*Available colors

- Silver (SLV)
- Black (BLK)
- White (WHT)

**\$575.00**

Slim



- Mobile Box/File Cabinet
- Locking 2 drawer cabinet (2 Keys)
- Small top drawer with pencil tray
- Large bottom file drawer
- Steel Construction
- Fits under all height adjustable desks
- Cushions available
- Product Size:
  - Slim: 11.8"W x 19.7"D x 18.5"H

LSE-MPBF-11-\*\_\*\_\*

\*\*\*Available colors

- Silver (SLV)
- Black (BLK)
- White (WHT)

**\$545.00**

Cushion

- Provides convenient additional seating
- Seat cushion adds approximately 1.2" h to pedestal
- Available in seven fabric colors
- Meets CAL-117 flammability standards
- EPA TSCA Title VI Compliant
- 100% Polyester Fabric
- 100% Polyurethane Foam
- Do not wash. Spot clean only using mild soap and water
- Warranty: 5-years

Standard

XXX-XXX-XX-\*\_\*\_\*

**\$199.00**

Slim

XXX-XXX-XX-\*\_\*\_\*

**\$175.00**

- Beige - BGW
- Black - BLK
- Cobalt Blue - BLU
- Carbon - CBN
- Gunmetal - GNM
- Pear Green - GRN
- Iced Grey - ICE



# Task Chair

**PRODUCT**

Air

**FEATURES****SEAT**

- 3.5" Molded Foam Seat with grade 1 fabric seat cover

**BACK**

- High Back breathable, stretchable nylon mesh
- High strength engineered frame
- Adjustable lumbar back support

**ARMS**

- 3D adjustable arms allowing adjustment in height, backward/forwards, and sideways angle with a 7" - 10" height range
- Durable cushioned arm pads

**CONTROLS**

- 4 lock positions, side tension, adjustable handles
- Synchro Tilt Mechanism with sliding seat pan adjustment
- Weight Capacity is 250 lbs.

**DIMENSIONS**

- 27"W x 25.6"D x 39" - 42.5"H

**CYLINDER & BASE**

- Standard Cylinder Height of 5"
- Seat Height Range of 16" - 20"
- Five Star Black Nylon Base
- Carpet Casters are standard
- Available in several color options

**MODEL NUMBER & LIST PRICE**

LSE-TC-AIR-BLK

Available colors

- Black (BLK)

**\$1,025.00**



# Cable Management

PRODUCT	FEATURES	MODEL NUMBER & LIST PRICE
---------	----------	---------------------------

Trough

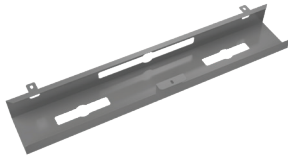

- Cable Trough constructed of steel to manage all of your wires and cables for your workspace.
- Front and rear access allows for ease of use for adding or removing wires and cables.
- Dimensions: 31.5"W x 5"D x 3"H
- Easy installation with only three screws.

LSE-CMT- \* \* \*

\*\*\*Available colors

● Silver (SLV)

● Black (BLK)

○ White (WHT)

**\$175.00**

Spine

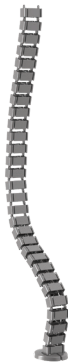

- Conceal and organize wires and cables beneath a height adjustable table to create an attractive, functional, and uncluttered workspace.
- Size: 2.7" x 1.4"
- Total Length: 50.4"
- Four cable channels inside the cable manager to separate power and data cables.
- Mounting Plate that attaches to the underside of the work surface.
- Weighted Base that sits on the floor to provide a stable base to route wires and cables.

LSE-CMS- \* \* \*

\*\*\*Available colors

● Silver (SLV)

● Black (BLK)

○ White (WHT)

**\$79.00**



# Lone Star Ergo Sustainability

## **OUR COMMITMENT**

Lone Star Ergo (LSE) has a core commitment to our people, products, and the planet. All individuals in our organization are committed to providing ergonomic and space optimization solutions that are sustainable supporting the healthy planet. LSE intentionally designs and measures for improvement constantly as a base line of who we are. We are an action forward company looking through the lens of design, form and function in supporting the health of the world in the intentions of our products.

## **LONG LASTING DURABLE PRODUCTS**

LSE designs our products with recyclable steel and aluminum materials to maximize the reuse of the individual main components. Our products are tested to meet the highest durability standards in the industry allowing consumers to use the product for twice the lifetime of other purveyors thus saving the environment by having longer life cycles of use.

## **COMMUNITY**

LSE gives back to the community by donating to the Shriners Hospital system in the support of keeping children healthy no matter what their financial circumstance. We fully support Shriners Hospital and their mission to heal Children with orthopedic conditions, burns, spinal cord injuries, and cleft lip and palate in a family-centered environment, regardless of the patients' ability to pay.

## **PACKAGING FOR OUR GLOBE**

Our shipping boxes are produced from 45% recycled material and 100% of the materials come from renewable pulp sources. Our packaging has been designed to ensure minimal impact on the Globe for material impact and can be recycled at local facilities 100% of the time.

# Lone Star Ergo Terms and Conditions:

For the most up to date product and ordering information refer to website [lonestarergo.com](http://lonestarergo.com)

Acceptance by Customer of products from Lone Star Ergo (Products) constitutes acceptance by Customer of these terms and conditions (Terms and Conditions). Any additional or different terms proposed by Customer shall be deemed to have not been approved or accepted by Lone Star Ergo. These Terms and Conditions constitute the entire agreement between both parties that have been objected by Lone Star Ergo, shall have no force or effect, and will not be binding upon or enforceable against Lone Star Ergo. These Terms and Conditions constitute the entire agreement and understanding between the parties and supersede any and all prior agreements, understandings and communications with the Dealer or Customer, oral or written, relating to the products. No course of dealing or course of performance, either prior to, during or after the delivery of the Products, shall be relevant or admissible by Customer to supplement, explain or vary these Terms and Conditions. No waiver, amendment or modification of these Terms and Conditions shall be binding upon or enforceable against the Seller until approved in Writing by a Lone Star Ergo Authorized Signatory.

## **DISCONTINUED PRODUCTS**

Due to Supply Chain and Market Demands – Lone Star Ergo may periodically discontinue certain products. Lone Star Ergo reserves the right to change and or discontinue products at any time without notice.

## **PAYMENT AND CREDIT TERMS**

To Open an account with Lone Star Ergo – Customer must complete and submit a new account application (signed by Company Officer), Federal Taxpayer ID (Form W9) and State Resale Certificate. Once approved, payment terms are net 15 days. 50% deposit on all orders above 8K net Payment for invoices can be facilitated with a Check or ACH. Credit cards are currently not available as payment.

In some cases – a deposit will be required due to the size of the order or terms of the credit approval.

## **PURCHASE ORDER SUBMISSION**

Purchase orders should be submitted via email to [Orders@lonestarergo.com](mailto:Orders@lonestarergo.com). Purchase orders should include the ship to and bill to information with the quote number or correct model numbers. Incomplete purchase orders will delay processing and shipment. Deposit checks must be received and processed before the shipment can be released.

## **ORDER CHANGES OR CANCELLATIONS**

All customer cancellations and changes must be submitted to Lone Star Ergo in writing before the product ships and has to be approved by Lone Star Ergo. Any adjustment in quantity is subject to an adjustment in pricing. Change or Cancellation requests will not be considered accepted until Lone Star Ergo sends back an adjusted invoice.

## **TAXES**

Lone Star Ergo (LSE) is not responsible for the collection of sales taxes on products sold to dealers. Dealers must provide Federal Tax payer ID (form W9) and State Resale Certificate to establish and account with LSE. Dealers are responsible for any sales or use taxes assessed if dealer requests drop ship direct to the dealer's customer.

## **SHIPPING AND FREIGHT TERMS**

Shipping is a Dock-to-Dock requirement to the 48 Contiguous States. Lone Star Ergo does not ship to residential customers. Freight Terms are as follows:

Height Adjustable Table Bases and Ergo Products will incur a freight charge of \$35.00 per unit, for orders consisting of 1 - 5 units. There will be no freight charges for orders of 6 or more units.

Chairs will incur a freight charge of \$50.00 per unit, for orders consisting of 1 - 5 units. There will be no freight charges for orders of 6 or more units.

Ergo Products (Monitor Arms and Power) charge a \$50.00 fee per order.

Projects will be quoted the correct freight charged by Lone Star Ergo.

Special requests such as "call before delivery", "Delivery Lift Gate Required" will be subject to additional fees and or may not be available.

## **WILL CALL**

Lone Star Ergo offers will call out of the Farmers Branch facility. Will Call will have to be arranged with Lone Star Ergo in advance. Will call orders will be invoiced the day the order is picked up or may require prepayment depending on the terms with the dealer.

## **DAMAGE CLAIMS OR SHORTAGES**

The dealer must notify carrier of damages or shortages at time of delivery. If the damage is concealed, Lone Star Ergo must be notified in 5 days from delivery to submit a claim or customer waives the right to submit a claim. Product must be in the original packaging and may be requested for photos and shipment back to Lone Star Ergo for evaluation.

## **WARRANTY**

All Height Adjustable Table Bases are under a 10-year warranty for all electrical and mechanical, and a limited lifetime warranty on the frame. LSE Monitor Arms have a 10-year warranty, LSE Power has a 5-year warranty. Please contact Lone Star Ergo warranty and troubleshooting requests.



877-746-2055 | [LoneStarErgo.com](http://LoneStarErgo.com)