

Pronto Series - P3

2-leg Electric Height Adjustable Table Base

Quick Install Quick Ship



LONE STAR ERGO

877-746-2055 | LoneStarErgo.com

Pronto Series - P3

2-leg Electric Height Adjustable Table Base

FEATURES

- Dual motor lifting system
- 3-Stage height adjustability
- Steel frame/foot construction (dual crossbar)
- Height Range: 21.1" – 47.2"
- Total Height Range: 26.1"
- Speed: 1.4"/Second
- Frame Width: 40.75" – 68.31"
- Quick Install Adjustable Frame
- Accommodates work surfaces 40" W to 72" W
- Maximum Weight Load: 300 lbs.
- Low standby power consumption
- Anti-Collision & Gyro Built-in
- Meets or exceeds BIFMA x5.5 guidelines
- Base is UL Listed E340036
- Includes 8.0' power cord
- Warranty: 10 yr. on electrical components
life time on structural components

OPTIONS

Available Colors

- Silver (SLV)
- Black (BLK)
- White (WHT)

Handset Options

- 3 memory touchpad with digital readout

Feet Options

- T Shape
- 24" or 30" Length Available

PRODUCT CODE:

List Price: \$1,200 (Base Only)

LSE-P3-T-* *-* * *

**Feet options

- T shape: 24" or 30"

***Available colors

- Silver (SLV)
- Black (BLK)
- White (WHT)

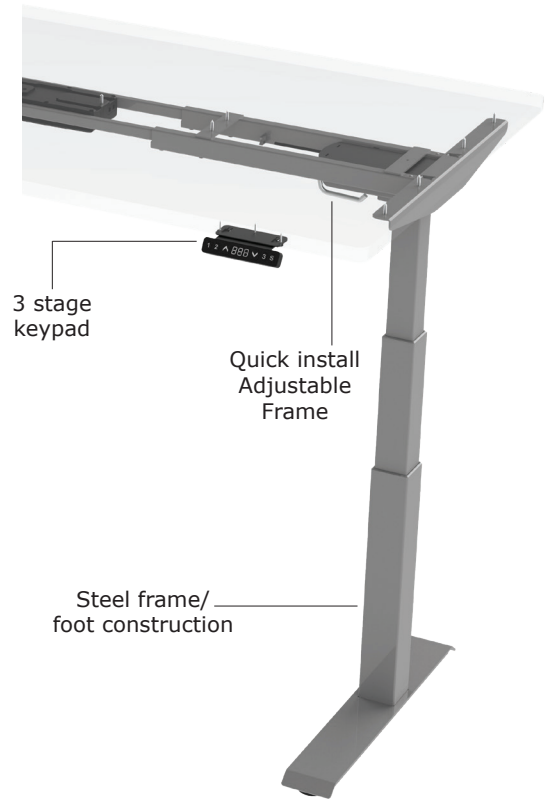

LONE STAR ERGO

877-746-2055 | LoneStarErgo.com